

# **EECE.3170: Microprocessor Systems Design I**

Summer 2017

## Lecture 9: Key Questions

June 7, 2017

1. Explain the major differences between a microprocessor and a microcontroller, including the typical features of a microcontroller.

2. Explain the major benefits and limitations of using a microcontroller.

3. Explain the general components of the PIC16F1829 block diagrams shown below.

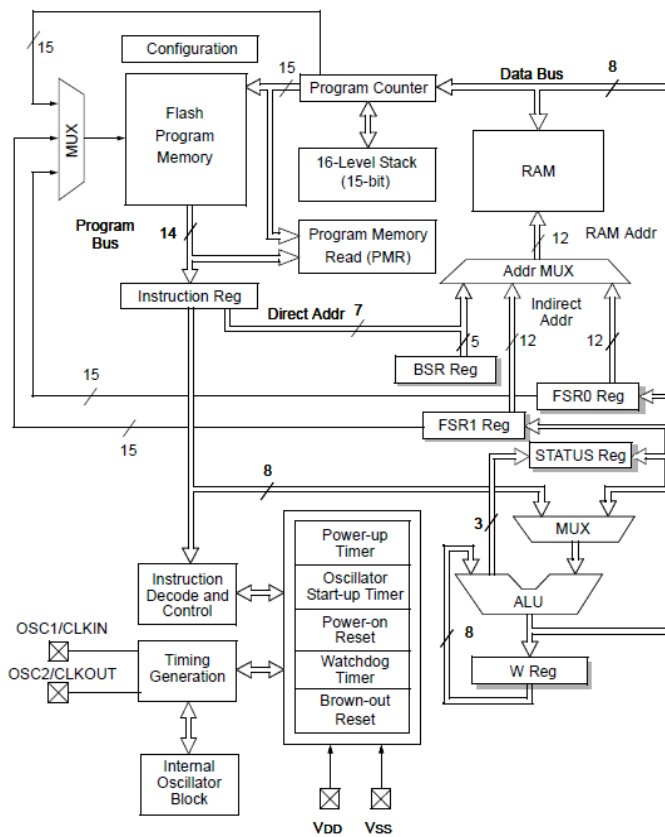
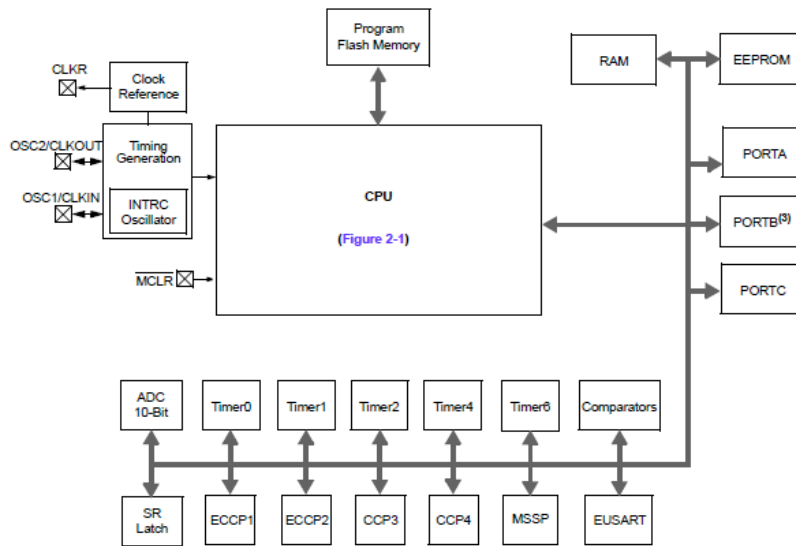

4. What is the difference between Harvard and von Neumann memory architectures?

5. Explain the basic organization of the PIC data memory.

6. Explain the purpose of the PCL and PCLATH registers.

7. Briefly describe the contents of the STATUS register.

8. Explain the basic organization of the PIC stack.

9. Explain how different memory banks are accessed in PIC microcontrollers.

10. Explain direct addressing on the PIC microcontrollers.

11. Describe the instruction formats of the PIC 16F1829.

12. Describe how variables can be declared in PIC assembly language.

13. Describe the PIC instructions for clearing or moving registers.



14. Describe the PIC instructions for manipulating a single bit.

15. **Example:** Show the values of all changed registers after the following sequence

```
cblock    0x30
    x
    y
endc
clrw
movwf    x
movlw    0xFE
movwf    y
swapf    Y, F
bcf      Y, 3
bsf      x, 3
movf     y, W
```

16. Describe the PIC instructions for increment, decrement, and complement operations.

17. Describe the PIC instructions for addition and subtraction.



18. **Example:** Show the values of all changed registers after the following sequence

```
cblock    0x20
    varA
    varB
    varC
endc
clrf     varA
clrf     varB
clrf     varC
incf     varA, W
sublw    0x0F
addwf    varB, F
decf     varB, F
comf     varB, W
subwf    varC, F
```