

16.317: Microprocessor Systems Design I

Spring 2016

Lecture 18: Key Questions March 9, 2016

1. Explain the major differences between a microprocessor and a microcontroller, including the typical features of a microcontroller.

2. Explain the major benefits and limitations of using a microcontroller.

3. Explain the general components of the PIC16F1829 block diagrams shown below.

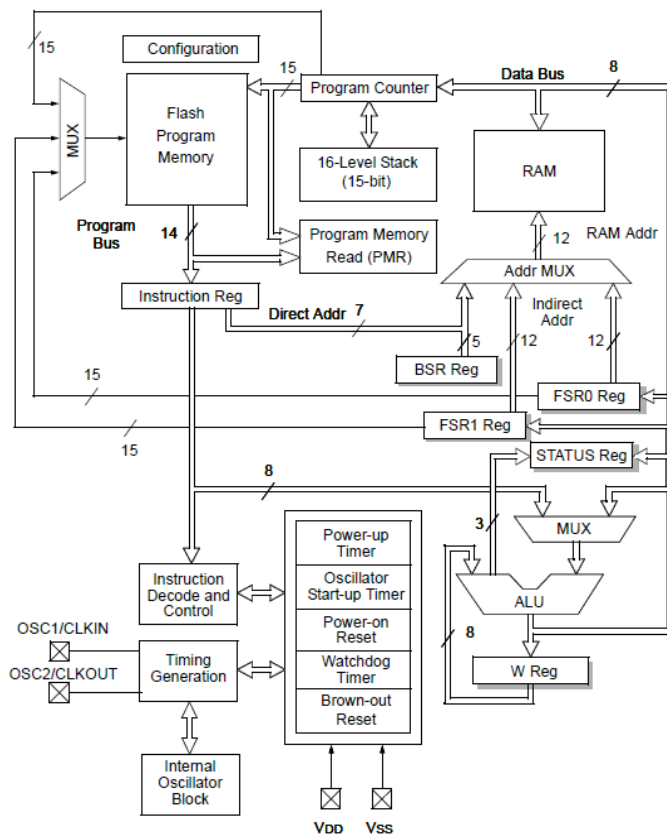
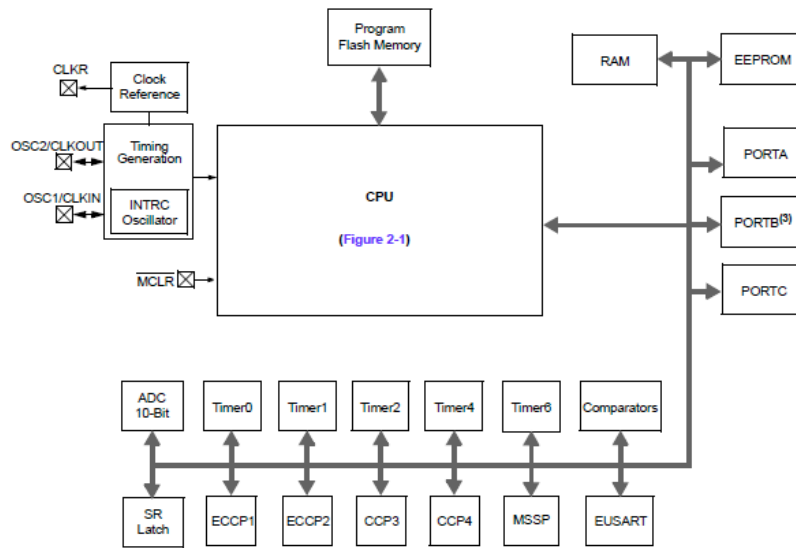

4. What is the difference between Harvard and von Neumann memory architectures?

5. Explain the basic organization of the PIC data memory.

6. Explain the purpose of the PCL and PCLATH registers.

